



The electronic double knob cylinder



Since autumn 2007 WILKA has completed its product range with a digital cylinder.

The new *easyDK* also can be used in objects in which transponder media are already used with Mifare ® technology. The battery operation with common alkali batteries ensures a simple refitting into existing doors.

An electronic reader for use in barrier installations, at rolling gates or in connection with motor-operated locks and cylinders rounds the pallet.

By the use of a mechatronical key the combination with mechanical WILKA keying systems and customer keyprofiles is also possible. Variants like electronic cylinders with both side electronic equipment, half cylinders and cylinders for emergency exit doors are possible.

An open and easily operable software serves the programming of the locking authorisations also in systems with more than 1,000 cylinders and 5,000 users. The system uses the unique ID-number of Mifare®-transponders for the identification at the doors. The users are assigned to accessible doors for them - also with an individual temporal authorisation by a locking plan. The complete locking plan is transferred to a portable programming device in order to update the doors fast and simply. The readout of the locking events – with date and time – is possible also on this way. By the communication of the programming device with the software a comparison of the access rights is possible at the door with the software data at any time in order to find out whether all units were updated with the latest data of locking plan.

Furthermore there is an application for hotels and seminar houses with writeable transponders as well as versions for integrating into a network variant. A simple system without software which is used only with a programming card is in preparation.



The electronic double knob cylinder

continuation page 2

The modular construction of the system is in the foreground. Only by software exchange the system configuration can be changed.

New in this product area on the occasion of the fair "fensterbau frontale" is an application for hotels and seminar houses with writeable transponders as well as a network variant and a simple system without software, which is used only with a programming card.

The modular structure of the system is in the foreground. Only by software exchange it is possible to switch over into another system configuration.

Two new cylinder versions are presented, an electronic half cylinder and furthermore a version of the double knob cylinder with electronics on both sides. By this way access and exit are possible to be controlled from inside and outside similarly.

As of now, the wall reader, developed by WILKA in outstanding design with stainless steel surface is also deliverable compatible to *the easyDK*.

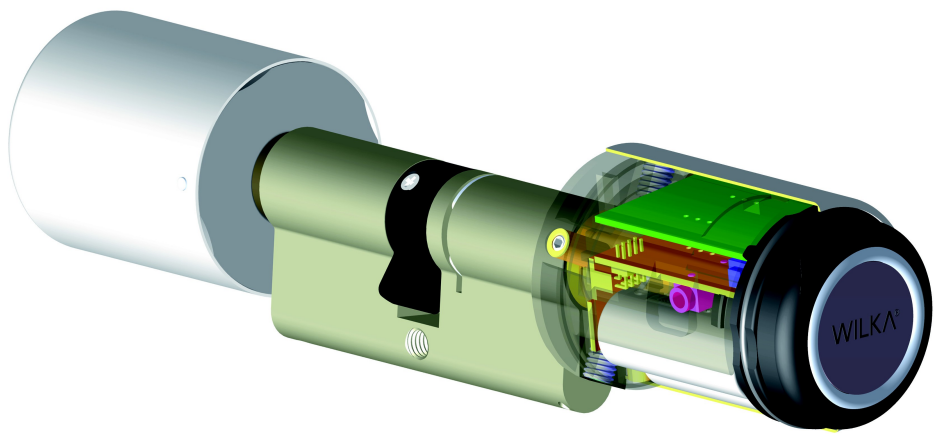
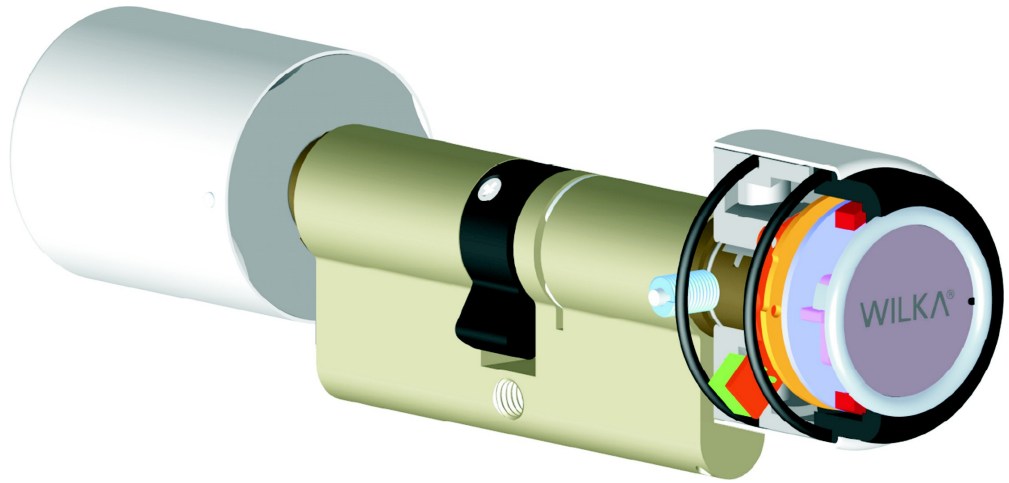

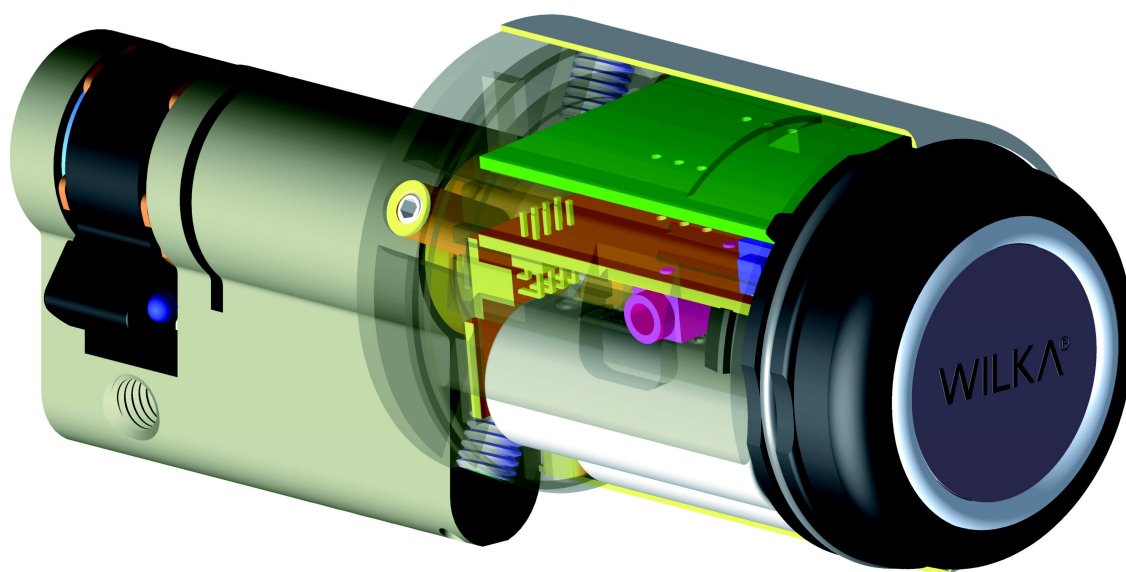

Contact: Christian Schwab * Fon +49 2051 2081113 * Email: c.schwab@wilka.de

WILKA Schließtechnik GmbH * www.wilka.de